

型號: S-292T / C-292T

壓力: 2000 PSI (140 kg/cm²)
 型式: 二片式·牙口·全流量

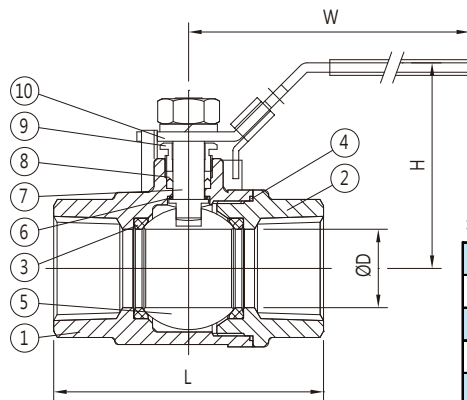
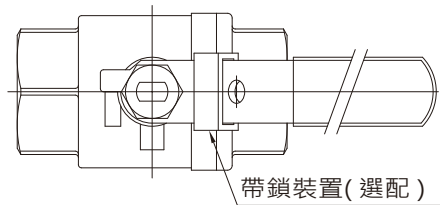

尺寸表:

尺寸	1/4"	3/8"	1/2"	3/4"	1"	1 1/4"	1 1/2"	2"	2 1/2"	3"	4"
ØD	11	12.5	15	20	25	32	38	50	65	80	100
L	55	55	65	71	86	98	111	126	162	180	231
H	53	53	53	56.5	65.5	71	81	89.5	128.5	139.5	167.5
W	94	94	111	111	111	137	167	167	243	243	274

單位:mm

材質表:

No.	名稱	S-292T	C-292T
1	閥體	CF8M (316)	WCB 碳鋼
2	閥蓋	CF8M (316)	WCB 碳鋼
3	球墊	RTFE	RTFE
4	大薄片	PTFE	PTFE
5	球	CF8M (316)	CF8 (304)
6	小薄片	PTFE	PTFE
7	中軸	316	304
8	中口	PTFE	PTFE
9	牛柄	304	304
10	把手	304	碳鋼