

型號: S-135W / C-135W

壓力: Class 150

型式: 一片式薄餅型, 法蘭口,
全流量

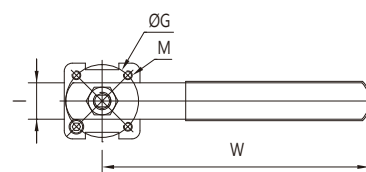
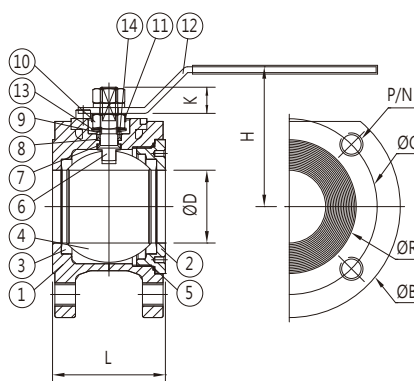

尺寸表:

單位:mm

尺寸	1/2"	3/4"	1"	1 1/4"	1 1/2"	2"	2 1/2"	3"	4"	6"
ØD	15	20	25	32	38	50	65	76	96	135
L	35	38	43	52	63	77.5	101	116	150	182
I	6	6	8	8	8	8	12	12	12	22
K	10.5	10.5	16.3	16.5	17	18	21	19.5	27	26.5
ØG	36	36	42	42	50	50	70	70	70	102
M	M5	M5	M5	M6	M6	M6	M8	M8	M8	Ø11
ØR	35.1	42.9	59	65	80	91.9	104.6	127	157.2	215.9
ØC	60.5	69.9	79.2	88.9	98.6	120.7	139.7	152.4	190.5	241.3
ØB	90	99	108	128	140	152.4	178	190.5	220	279.4
P	1/2"-13 UNC	1/2"-13 UNC	1/2"-13 UNC	1/2"-13 UNC	1/2"-13 UNC	5/8"-11 UNC	5/8"-11 UNC	5/8"-11 UNC	5/8"-11 UNC	3/4"-10 UNC
N	4	4	4	4	4	4	4	4	8	8
H	63	68	92	94	89.5	96.5	128.5	146.5	167.5	215
W	135	135	135	135	175	175	243	243	285	460

材質表:

No.	名稱	S-135W	C-135W
1	閥體	CF8M (316)	WCB 碳鋼
2	閥蓋	CF8M (316)	WCB 碳鋼
3	球墊	PTFE	PTFE
4	球	CF8M (316)	CF8 (304)
5	大薄片	PTFE	PTFE
6	中軸	316	304
7	小薄片	PTFE	PTFE
8	中口	PTFE	PTFE
9	牛柄	304	304
10	中口螺帽	304	304
11	防鬆墊圈	304	304
12	把手	304	碳鋼
13	盤型彈片	301	301
14	中口保護片	加碳25%PTFE	加碳25%PTFE