

2-PIECE STANDARD PORT BALL VALVES

FIG. S-212T / C-212T: THREADED ENDS, 2000 PSI(138 BAR) W.O.G..

FEATURES:

- Reinforced TFE seats increase durability.
- Adjustable packing gland.
- Bottom-loaded blow-out proof stem.
- Basic design complied with ANSI B16.34 & EN 12516-1.
- NPT threaded ends complied with ANSI B 1.20.1..
- Rc, Rp & G Threaded ends complied with BS 21/2779, JIS B-0203/0202, DIN 259/2999, ISO 228-1, AS1722.1/1722.2 are upon request.
- Tested according to API 598.



MATERIALS LIST:

NO.	PARTS	S-212T	C-212T
1	BODY	ASTM A351-CF8M	ASTM A216-WCB
2	SEAT	REINFORCED PTFE	REINFORCED PTFE
3	BALL	ASTM A351-CF8M/316	ASTM A351-CF8/304
4	GASKET	PTFE	PTFE
5	END CAP	ASTM A351-CF8M	ASTM A216-WCB
6	HANDLE NUT	AISI 304	AISI 304
7	HANDLE WASHER	AISI 304	AISI 304
8	GLAND	AISI 304	AISI 304
9	STEM PACKING	PTFE	PTFE
10	THRUST WASHER	PTFE	PTFE
11	STEM	ASTM A276-316	ASTM A276-304
12	HANDLE	AISI 304	ZINC PLATED STEEL
13	HANDLE COVER	PVC	PVC

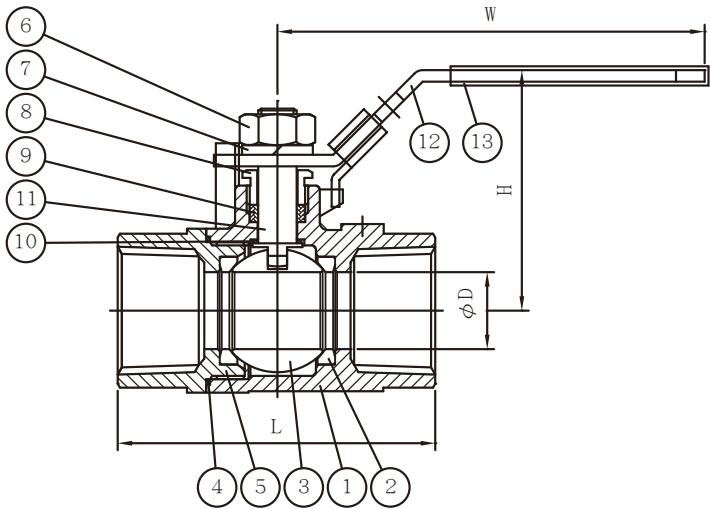
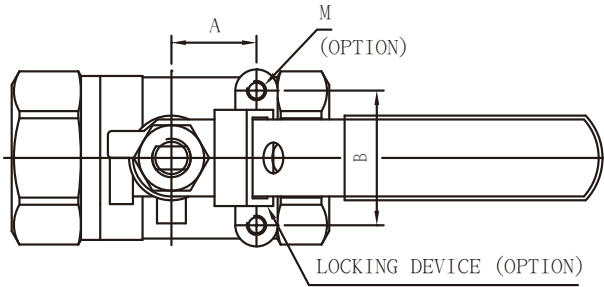

OPTIONS:

- L: LOCKING DEVICE. -V: VENTED BALL.
- M: TAPPED MOUNTING PAD. -W: BODY JOINT FULLY WELDED.
- A: ANTI-STATIC DEVICE.

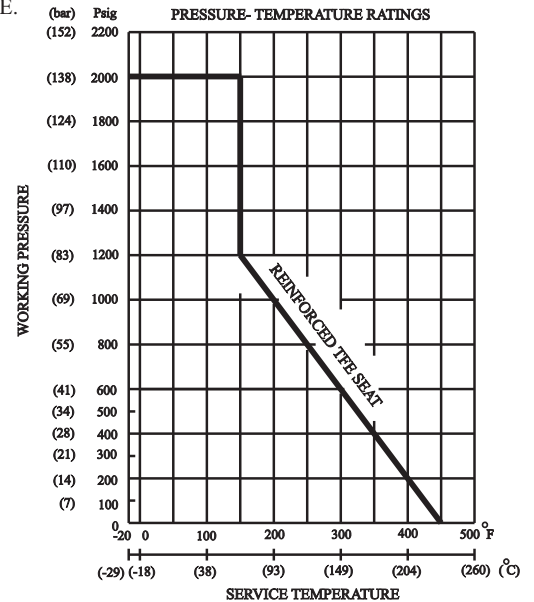

DIMENSIONS

SIZE		φ D		L		A		B		H		W		M
inch	DN	in	mm	in	mm	in	mm	in	mm	in	mm	in	mm	(OPTION)
1/4"	8	0.37	9.5	2.09	53	0.50	12.7	1.12	28.5	2.13	54	3.70	94	10-24UNC
3/8"	10	0.37	9.5	2.09	53	0.50	12.7	1.12	28.5	2.13	54	3.70	94	10-24UNC
1/2"	15	0.49	12.5	2.38	60.5	0.50	12.7	1.12	28.5	2.13	54	3.70	94	10-24UNC
3/4"	20	0.59	15	2.70	68.5	0.50	12.7	1.12	28.5	2.24	57	3.70	94	10-24UNC
1"	25	0.79	20	3.25	82.5	0.87	22.1	1.38	35	2.46	62.5	4.37	111	10-24UNC
1 1/4"	32	0.98	25	3.58	91	0.93	23.6	1.38	35	2.87	73	5.37	136.5	10-24UNC
1 1/2"	40	1.26	32	3.94	100	0.93	23.6	1.50	38.1	3.09	78.5	5.37	136.5	1/4-20UNC
2"	50	1.50	38	4.61	117	0.93	23.6	1.50	38.1	3.48	88.5	6.57	167	1/4-20UNC