

2-PIECE BALL VALVES

FIG. S-203T / C-203T: THREADED ENDS, 3000 PSI (207 BAR) W.O.G., 1/4" TO 1 1/2": FULL PORT, 2": STANDARD PORT, 3": FOR PORT.

FEATURES:

- Strengthened construction secures 3000 psi working pressure rating. Enlarged bottom-loaded blow-out proof stem.
- Gasket is placed ahead of the body cap threads, providing a tight seal and protection of threads from flow media.
- Vented ball equalizes pressure between the body cavity and the flow stream to prevent seat damage due to thermal cycling.
- Basic design complied with ANSI B16.34 & EN 12516-1.
- NPT threaded ends complied with ANSI B 1.20.1..
- Rc, Rp & G Threaded ends complied with BS 21/2779, JIS B-0203/0202, DIN 259/2999, ISO 228-1, AS1722.1/1722.2 are upon request.
- Tested according to API 598.



MATERIALS LIST:

NO.	PARTS	S-203T	C-203T
1	BODY	ASTMA351-CF8M	ASTMA216-WCB
2	END CAP	ASTMA351-CF8M	ASTMA216-WCB
3	SEAT	DELTRIN	DELTRIN
4	BALL	ASTMA351-CF8M / 316	ASTMA351-CF8 / 304
5	GASKET	PTFE	PTFE
6	THRUST WASHER	PTFE	PTFE
7	STEM	ASTMA276-316	ASTMA276-304
8	STEM PACKING	PTFE	PTFE
9	GLAND	AISI 304	AISI 304
10	HANDLE	AISI 304	ZINC PLATED STEEL
11	HANDLE WASHER	AISI 304	AISI 304
12	HANDLE NUT	AISI 304	AISI 304
13	HANDLE COVER	PVC	PVC

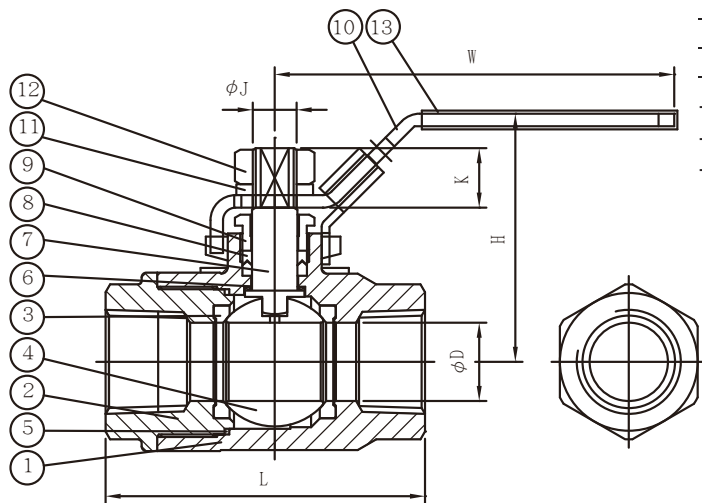
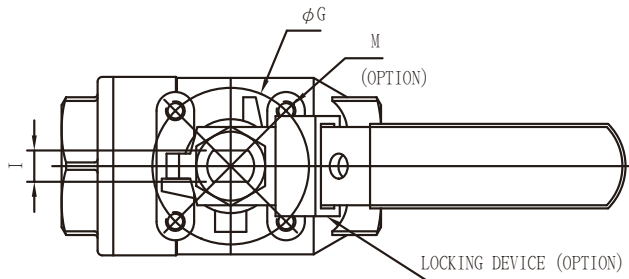

OPTIONS:

- L : LOCKING DEVICE.
- M: TAPPED MOUNTING PAD.
- F : FIRE - SAFE DESIGN.
- W: BODY JOINT FULLY WELDED.
- O: VITON O-RING ON STEM.
- A: ANTI-STATIC DEVICE.

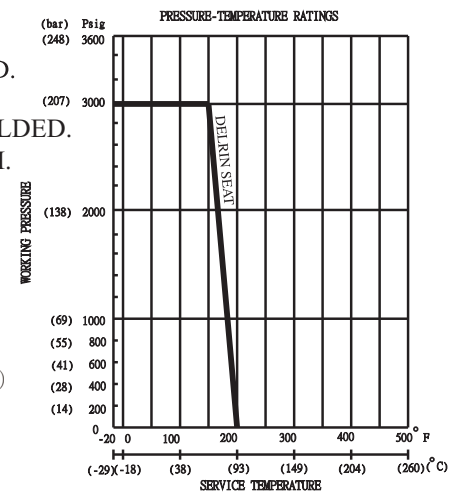

FOR 1/4"~ 3/4"

DIMENSIONS

SIZE		φD		L		H		W		I	φJ		K		φG		A	B	M			
in	DN	in	mm	in	mm	in	mm	in	mm	in	mm	in	mm	in	mm	in	mm	in		mm		
1/4"	8	0.37	9.5	2.52	64	2.13	54	3.70	94	0.20	5	0.31	8	0.37	9.5	-	-	0.50	12.7	1.12	28.5	M5-P0.8
3/8"	10	0.37	9.5	2.52	64	2.13	54	3.70	94	0.20	5	0.31	8	0.37	9.5	-	-	0.50	12.7	1.12	28.5	M5-P0.8
1/2"	15	0.49	12.5	2.83	72	2.13	54	4.37	111	0.20	5	0.31	8	0.37	9.5	-	-	0.50	12.7	1.12	28.5	M5-P0.8
3/4"	20	0.79	20	3.50	89	2.50	63.5	4.37	111	0.28	7	0.39	10	0.55	14	-	-	0.87	22.1	1.38	35	M5-P0.8
1"	25	0.98	25	4.02	102	3.11	79	6.57	167	0.39	10	0.55	14	0.75	19	1.97	50	-	-	-	-	M6-P1
1 1/4"	32	1.26	32	4.57	116	3.31	84	6.57	167	0.39	10	0.55	14	0.79	20	1.97	50	-	-	-	-	M6-P1
1 1/2"	40	1.50	38	4.88	124	4.29	109	8.66	220	0.47	12	0.75	19	1.14	29	2.76	70	-	-	-	-	M8-P1.25
2"	50	1.50	38	5.51	140	4.29	109	8.66	220	0.47	12	0.75	19	1.14	29	2.76	70	-	-	-	-	M8-P1.25
3"	80	3.15	80	8.07	205	5.94	151	14.57	370	0.63	16	0.98	25	1.34	34	4.02	102	-	-	-	-	M10-P1.5