

## 2-PIECE FULL PORT BALL VALVES

**FIG. S-202T / C-202T: THREADED ENDS, 1/4" TO 2": 2000 PSI (138 BAR) W.O.G.,  
2 1/2" TO 4": 1500 PSI (103 BAR) W.O.G..**

### FEATURES:

- Strengthened construction secures 2000 psi working pressure rating. Reinforced TFE seats increase durability.
- Adjustable packing gland.
- Bottom-loaded blow-out proof stem.
- Basic design complied with ANSI B16.34 & EN 12516-1.
- NPT threaded ends complied with ANSI B 1.20.1..
- Rc, Rp & G Threaded ends complied with BS 21/2779, JIS B-0203/0202, DIN 259/2999, ISO 228-1, AS1722.1/1722.2 are upon request.
- Tested according to API 598.



### MATERIALS LIST:

NO.	PARTS	S-202T	C-202T
1	BODY	ASTMA351-CF8M	ASTMA216-WCB
2	END CAP	ASTMA351-CF8M	ASTMA216-WCB
3	SEAT	REINFORCED TFE	REINFORCED TFE
4	BALL	ASTMA351-CF8M/316	ASTMA351-CF8/304
5	THRUST WASHER	PTFE	PTFE
6	GASKET	PTFE	PTFE
7	STEM	ASTMA276-316	ASTMA276-304
8	STEM PACKING	PTFE	PTFE
9	GLAND	AISI 304	AISI 304
10	HANDLE WASHER	AISI 304	AISI 304
11	HANDLE NUT	AISI 304	AISI 304
12	HANDLE	AISI 304	ZINC PLATED STEEL
13	HANDLE COVER	PVC	PVC

### OPTIONS:

- F: FIRE-SAFE DESIGN.
- L: LOCKING DEVICE.
- M: TAPPED MOUNTING PAD.
- V: VENTED BALL.

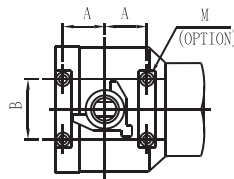
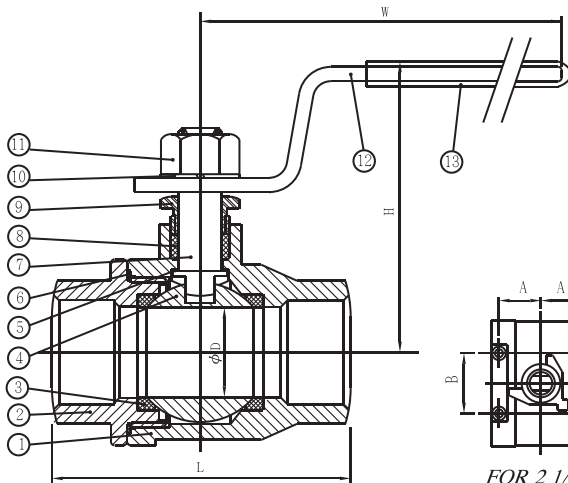
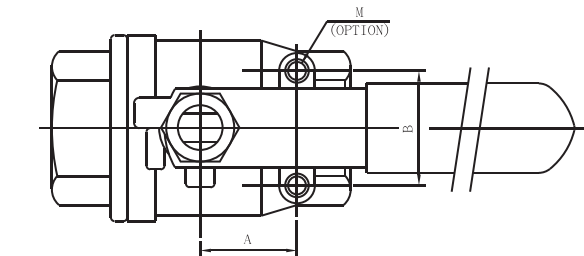

FOR 2 1/2"~3"

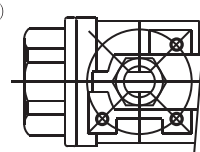

FOR 4"

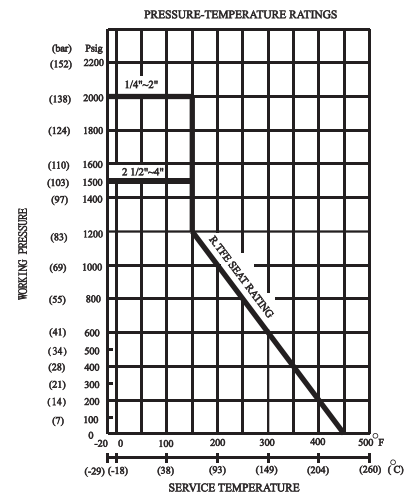

### DIMENSIONS

SIZE		φD		L		A		B		H		W		M (OPTION)
in	mm	in	mm	in	mm	in	mm	in	mm	in	mm	in	mm	
1/4"	8	0.43	11	2.24	57	0.50	12.7	1.12	28.5	2.13	54	3.70	94	10-24UNC
3/8"	10	0.49	12.5	2.24	57	0.50	12.7	1.12	28.5	2.13	54	3.70	94	10-24UNC
1/2"	15	0.59	15	2.54	64.5	0.50	12.7	1.12	28.5	2.24	57	3.70	94	10-24UNC
3/4"	20	0.79	20	2.87	73	0.87	22.1	1.38	35	2.46	62.5	4.37	111	10-24UNC
1"	25	1.00	25.4	3.37	85.5	0.93	23.6	1.38	35	2.87	73	5.37	136.5	10-24UNC
1 1/4"	32	1.26	32	3.94	100	0.93	23.6	1.50	38.1	3.09	78.5	5.37	136.5	1/4-20UNC
1 1/2"	40	1.50	38	4.41	112	0.93	23.6	1.50	38.1	3.48	88.5	6.57	167	1/4-20UNC
2"	50	1.97	50	5.12	130	0.93	23.6	1.50	38.1	3.84	97.5	6.57	167	1/4-20UNC
2 1/2"	65	2.56	65	6.38	162	1.38	35.0	2.17	55.0	5.06	128.5	9.57	243	1/4-20UNC
3"	80	3.15	80	7.09	180	1.38	35.0	2.17	55.0	5.49	139.5	9.57	243	1/4-20UNC
4"	100	3.94	100	9.09	231	-	-	-	-	6.59	167.5	10.79	274	M10

We reserve the rights to modify our product design or construction for improvement without prior notice.