

## 1-PIECE REDUCED PORT BALL VALVES

**FIG. S-141T / C-141T: THREADED ENDS, LENGTHENED BODY, 1000 PSI (69 BAR) W.O.G..**

### FEATURES:

- Lengthened body complied with DIN 3202-4 M3 standard.
- Belleville washer assures leak-free seal on cool-down and as packing wears. Bottom-loaded blow-out proof stem.
- Basic design complied with ANSI B16.34, DIN 3339, DIN 3357-1, DIN 3357-2, & EN 12516-1 .
- Face-to-face dimensions complied with DIN 3202-4.
- NPT threaded ends complied with ANSI B 1.20.1..
- Rc, Rp & G Threaded ends complied with BS 21/2779, JIS B-0203/0202, DIN 259/2999, ISO 228-1, AS1722.1/1722.2 are upon request.
- Tested according to API 598, DIN 3357-1 & DIN 3230-3 (strength & leakage test).

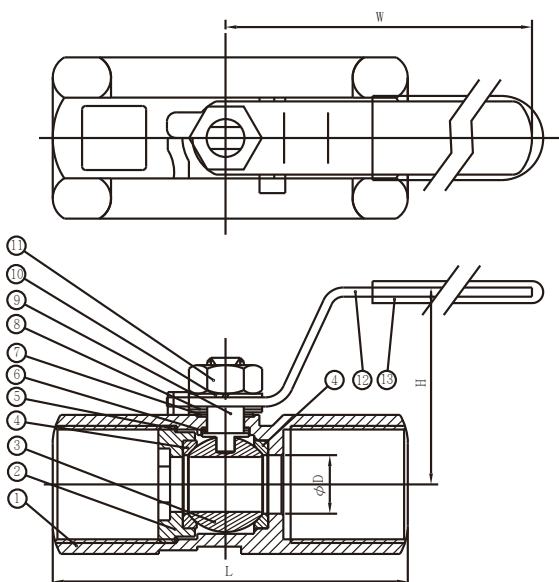

### MATERIALS LIST:

NO.	PARTS	S-141T	C-141T
1	BODY	DIN EN10213-4 1.4408 / CF8M	DIN EN10213-2 1.0619 / WCB
2	RETAINER	DIN EN10213-4 1.4408 / CF8M	DIN EN10213-2 1.0619 / WCB
3	BALL	DIN EN10213-4 1.4408 / CF8M	DIN EN10213-4 1.4308 / CF8
4	SEAT	PTFE	PTFE
5	GASKET	PTFE	PTFE
6	THRUST WASHER	PTFE	PTFE
7	STEM PACKING	PTFE	PTFE
8	BELLEVILLE WASHER	AISI 301	AISI 301
9	STEM	DIN 17440 1.4401 / AISI 316	DIN 17440 1.4301 / AISI 304
10	HANDLE WASHER	DIN 17440 1.4401 / AISI 304	DIN 17440 1.4301 / AISI 304
11	HANDLE NUT	DIN 17440 1.4401 / AISI 304	DIN 17440 1.4301 / AISI 304
12	HANDLE	AISI 304	ZINC PLATED STEEL
13	HANDLE COVER	PVC	PVC

### OPTIONS:

- L: LOCKING DEVICE.
- V: VENTED BALL.

### DIMENSIONS

SIZE		φD		L		H		W	
in	mm	in	mm	in	mm	in	mm	in	mm
1/4"	8	0.20	5	2.17	55	1.30	33	2.68	68
3/8"	10	0.28	7	2.36	60	1.38	35	3.11	79
1/2"	15	0.36	9.2	2.95	75	1.65	42	3.54	90
3/4"	20	0.49	12.5	3.15	80	1.81	46	3.54	90
1"	25	0.63	16	3.54	90	1.97	50	4.09	104
1 1/4"	32	0.79	20	4.33	110	2.20	56	4.09	104
1 1/2"	40	0.98	25	4.72	120	2.60	66	4.96	126
2"	50	1.26	32	5.51	140	2.83	72	4.96	126

