

## 1-PIECE REDUCED PORT BALL VALVES

**FIG. S-122T-F / C-122T-F: 1/2" TO 2", API 607 FIRE-SAFE DESIGNED.**

### FEATURES:

- Strengthened construction secures 2000 psi working pressure rating. Reinforced TFE seats increase durability.
- Separating packing nut and handle nut secures NO STEM LEAKAGE even when handle is removed.
- Belleville washer assures leak-free seal on cool-down and as packing wears.
- Bottom-loaded blow-out proof stem.
- Basic design complied with ANSI B16.34 & EN 12516-1 .
- NPT threaded ends complied with ANSI B 1.20.1..
- Rc, Rp & G Threaded ends complied with BS 21/2779, JIS B-0203/0202, DIN 259/2999, ISO 228-1, AS1722.1/1722.2 are upon request.
- Graphite gasket & stem packing prevent post-fire external leakage.
- Post-fire metal-to-metal seal prevents internal leakage after fire.
- Tested according to API 598.



### MATERIALS LIST:

NO.	PARTS	S-122T-F	C-122T-F
1	BODY	ASTM A351-CF8M	ASTM A216-WCB
2	RETAINER NUT	ASTM A351-CF8M/316	ASTM A216-WCB/A108
3	GASKET	GRAPHITE	GRAPHITE
4	SEAT RETAINER	ASTM A351-CF8M/316	ASTM A216-WCB/A108
5	BALL	ASTM A351-CF8M/316	ASTM A351-CF8/304
6	SEAT	REINFORCED TFE	REINFORCED TFE
7	THRUST WASHER	PTFE	PTFE
8	STEM PACKING	GRAPHITE	GRAPHITE
9	GLAND	AISI 304	AISI 304
10	STEM	ASTM A276-316	ASTM A276-304
11	BELLEVILLE WASHER	AISI 301	AISI 301
12	PACKING NUT	AISI 304	AISI 304
13	HANDLE COVER	PVC	PVC
14	HANDLE	AISI 304	ZINC PLATED STEEL
15	HANDLE NUT	AISI 304	ZINC PLATED STEEL

### OPTIONS:

- L: LOCKING DEVICE.
- M: TAPPED MOUNTING PAD.
- V: VENTED BALL.

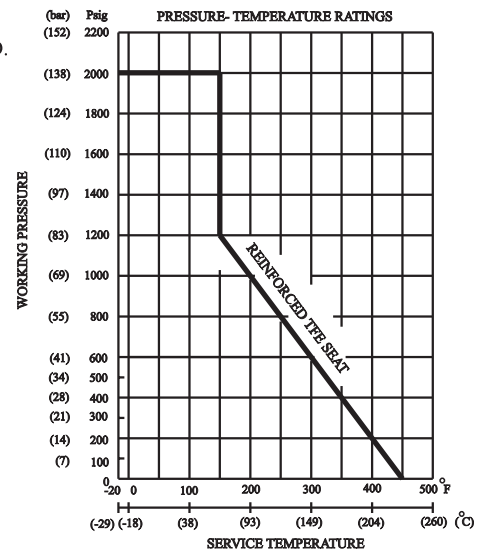
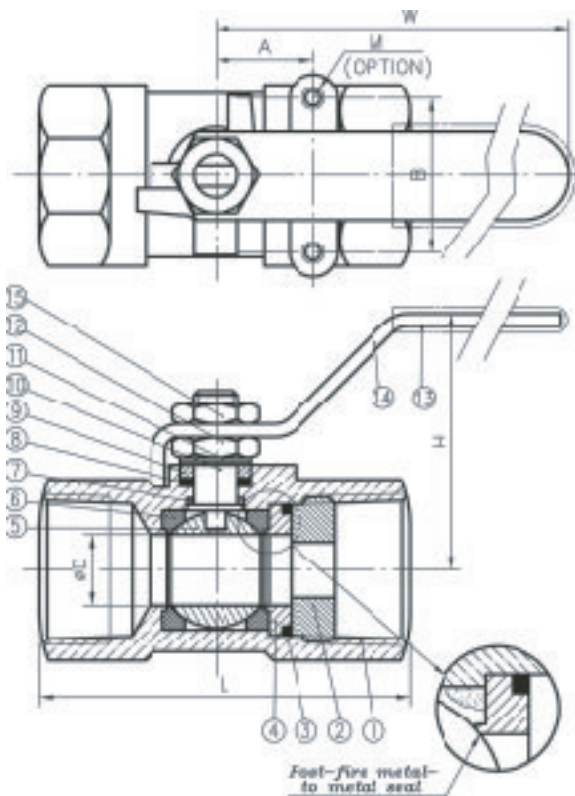

### DIMENSIONS

SIZE		φD		L		A		B		H		W		M
in	mm	in	mm	in	mm	in	mm	in	mm	in	mm	in	mm	(OPTION)
1/2"	15	0.36	9.2	2.64	67	0.50	12.7	1.12	28.5	1.73	44	4.37	111	10-24UNC
3/4"	20	0.49	12.5	2.80	71	0.50	12.7	1.12	28.5	1.89	48	4.37	111	10-24UNC
1"	25	0.63	16	3.35	85	0.87	22.1	1.37	34.8	2.36	60	5.55	141	10-24UNC
1 1/4"	32	0.79	20	3.70	94	0.87	22.1	1.37	34.8	2.56	65	5.55	141	10-24UNC
1 1/2"	40	0.98	25	3.94	100	0.93	23.6	1.50	38.1	2.80	71	6.34	161	1/4-20UNC
2"	50	1.26	32	4.65	118	0.93	23.6	1.50	38.1	3.03	77	6.34	161	1/4-20UNC